



Features

- Proprietary Interference Filtering Algorithm
- Small form factor: 74x 47x 25mm, 150g
- power consumption: < 1W
- Jamming detection alarm
- IP67 waterproof rating
- Automotive temperature grade compliant
- Protected frequency: GPS L1 (C/A Code)
- Passthrough frequencies: GPS L2/L5/GLONASS G1
- Latency: 100ns ±15ns (fixed)



Available also in OEM version

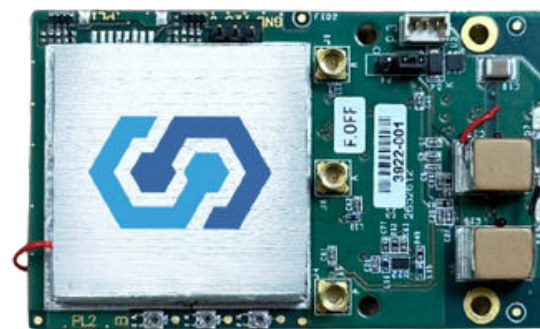

35g
OEM
Solution

How does it work?

The Vulnerability of GNSS is well understood. The satellites orbit at 20,000 KM altitude and emit a signal which is incredibly weak when received by GNSS receivers (~-125dBm). It is a simple matter to overpower this signal with a jammer bought online to block it.

Our unique interference filtering algorithm combines the patterns from two omni-directional antennas. OtoSphere analyzes where the interference is coming from and feeds it into its algorithm to filter out the jamming signals.

Installation Couldn't Be Easier just mount the 2 antennas on a flat, sky-facing base with at least 10cm separation (optimally > 25cm), connect the antennas through OtoSphere, connect OtoSphere to the antenna input on your GNSS receiver and feed it with power.

Jamming Detection is available from a LED on the unit itself or via a data output from the device which can be directly integrated to external systems.

Completely Standalone OtoSphere is compatible with almost any GNSS receiver on the market as well as most off-the-shelf active GNSS antennas. OtoSphere does not include the GNSS receiver or the antennas.

OtoSphere – GNSS Protection

Industry's only commercial GNSS protection solution

The OtoSphere module is fully retrofit and easy to install – connect to any existing GNSS receiver and any two standard, off-the-shelf antennas

- The OtoSphere attenuates and filters the effect of a jamming attack
- It makes any receiver at least **20x** more resilient to attacks
- Allows for operation in GNSS challenged environments
- It is versatile and can protect ground, sea and aerial platforms





Product Diagram



Product Dimensions

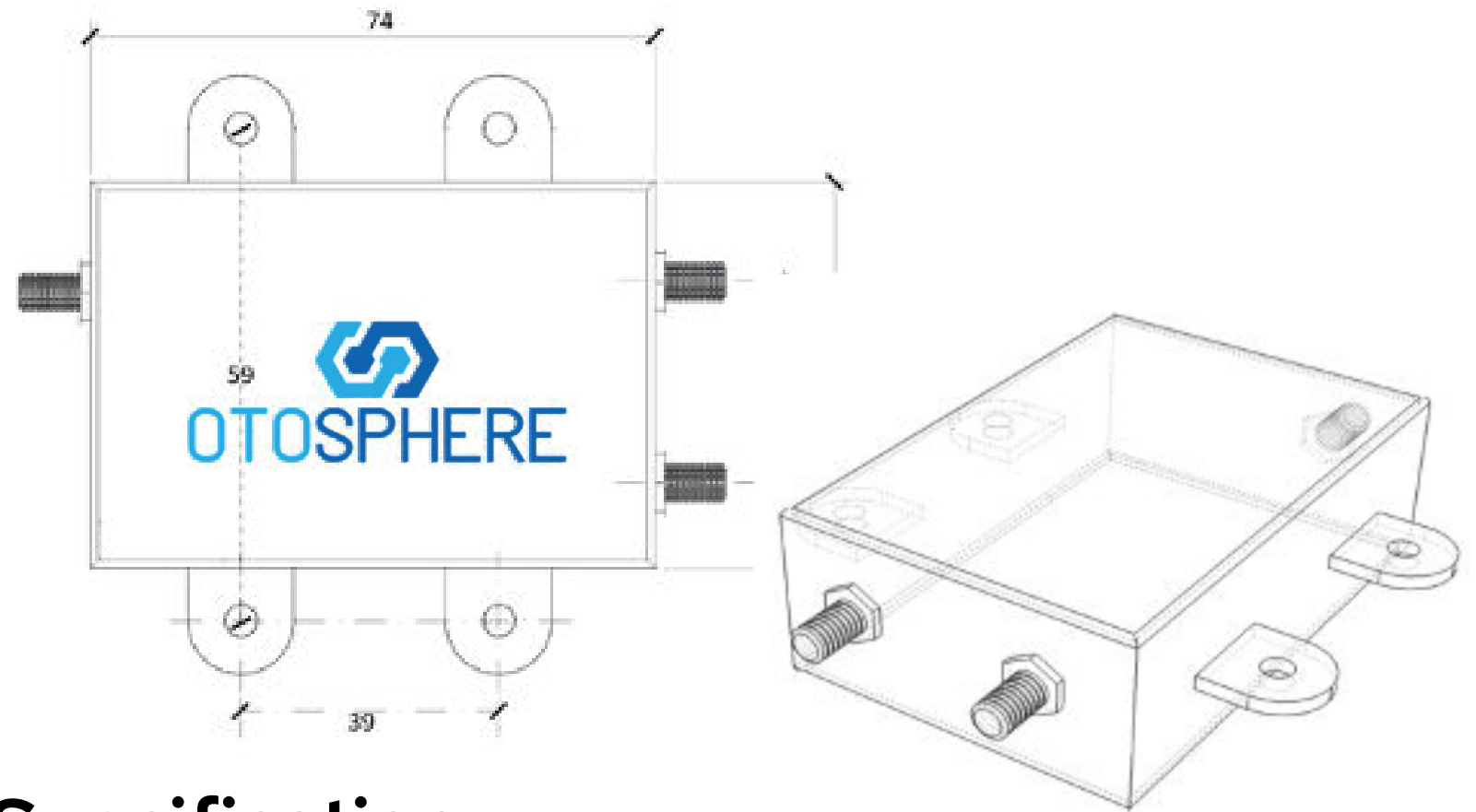

Product Specifications

Physical	
Dimensions	74mm x 47mm x 25mm (excluding mounting lugs)
Weight	150g
Mounting	4 x M3 bolts (not supplied)
OEM	
Dimensions	40mm x 65mm x 11mm (excluding mounting lugs)
Weight	35g
Mounting	4 x M2.5 bolts (not supplied)

Performance	
Protected Signal	1575.42 MHz (GPS L1 C/A Code)
Passthrough additional 2 GNSS signals	GPS L2 / L5 / Glonass G1
Latency	100ns ±15ns (fixed)
Compression Point	25dBm
Insertion Loss	±2dB
Environmental (enclosed unit)	
Operating Temperature Range	-40°C to 85°C
Waterproof Rating	IP67

Safety & Compliance	
FCC Compliant	
CE Compliant	
RoHS Compliant	
EPS Product Wire Connection Description	
Red Wire	3.7 - 32VDC <1W
Black Wire	GND
Brown & White	Open drain interference detection
RF Interfaces	
Antenna Connectors (P/A)	50Ω SMA 2.75 - 3.3VDC, designed for 26dB ±2dB gain
Receiver Connector (R)	50Ω SMA requires 3.7 - 32VDC <1W

Ordering Information

OtoSphere — 01 — X — X | X

Protected frequency: 1 - GPS L1	Connector/Cable P - Phantom power supply (over RF cable) E - external cable	Passthrough frequency (optional): 0 - null 2 - GPS L2 3 - GPS L5 4 - GLONASS G1
---	--	--

