



## GPSdome 1.03 - EPS

### Installation Manual v1.2

INFINIDOME – NAVIGATION RESILIENCY

## Contents

Introduction .....	2
Interfaces .....	3
<b>Cautions</b> .....	4
Technical Specification.....	4
Installation .....	5
Before installation.....	5
Unpacking and inspecting equipment .....	5
Where to install.....	5
GPS Receiver System with GPSdome .....	6
SMA Cables Connectors .....	6
Installation procedure.....	7
General Operation .....	10
Help and Support .....	11
General Specifications and Antenna Parameters .....	11
Maintenance .....	12
Troubleshooting.....	12
Problem: Nothing is working, and my GPS receiver does not acquire lock.....	12
Interference Indication .....	13
Interference Indication Integration Instructions .....	13
Indication specification .....	13
Knowing issues.....	13
PPS installation.....	14
PoRF .....	14

## Introduction

Thank you for buying GPSdome.

**GPSdome is a small, add-on module to any GNSS-based system that protects it from GNSS jamming attacks.**

GPSdome ensures continuity of autonomous navigation and operation during jamming conditions. No other solution that offers such protection is as small, light, affordable or as easily installed as GPSdome. The unit may be installed on a range of installations that rely on GPS and connects between the antenna and the GPS receiver.

Two active GPS antennas, with nominal gain of 26dB, are connected to the SMA RF connectors; the primary and auxiliary antenna inputs. The RF Output provides connection to the input of the GPS Receiver.

---

## Interfaces

(R) output to the GPS receiver SMA.

Primary Antenna Input (P) - 50Ω SMA 2.75VDC designed for 26dB ±2dB gain.

Auxiliary Antenna Input (A) - 50Ω SMA 2.75VDC designed for 26dB ±2dB gain.

Power Harness		
● RED	RED	3.7VDC – 32VDC (0.75W)
● BLACK	BLACK	GND
● BROWN	BROWN	Open drain interference indication. (This wire sends an indication when the unit is detecting and protecting against a hostile signal).



Figure 1 – GPSdome 1.03 - EPS - General Overview

## Cautions

1. The GPSdome module should be mounted on a flat surface where possible and secured using the mounting holes provided.
2. To prevent damage to any cable assemblies used in this installation, ensure the cables are not bent, deformed or snagged to cause damage to the internal wiring or the connector ends.
3. This product is a high-tech electronics module, installation must be performed by a professional installer.
4. During installation ensure there is NO power applied to the module. Make sure the GPS receiver is powered off.

## Technical Specification

Physical	
Enclosure	74mm x 47mm x 25mm (excluding mounting lugs)
Weight	150g
Mounting	4 x M3 bolts (not supplied)
Environmental	
Operating Temperature Range	-40°C to 85°C
Waterproof Rating	IP67
Safety & Compliance	
FCC	
RoHS compliant	
CE Compliant	
RF Interfaces	
Antenna Connectors (P/A)	50Ω SMA 2.75VDC designed for 26dB ±2dB gain
Receiver Connector (R)	50Ω SMA

## Installation

### Before installation

Please verify that the following equipment is available:

- GPSdome 1.03b – EPS
- 2 units of 26dB  $\pm$ 2dB gain antennas, 2.75VDC (from the same type) with 50 $\Omega$  cable and SMA connector (length of the cables should be identical).
- SMA coax cable from GPSdome (R) connector to the GNSS receiver
- RF converters to SMA (if needed)
- 3.7VDC – 32VDC power source

### Unpacking and inspecting equipment

When unpacking equipment, make a visual inspection for evidence of damage incurred during shipment. The following parts should be included:

- (R), (P) & (A) SMA connector – please verify that the connectors are not damaged, and the thread is complete.
- Verify that the external power supply is not damaged.
- Make sure that the unit does not have any dents.

### Where to install

**GPSdome** – locate and secure the GPSdome with the power cable appropriately sized to reach the power source and the antenna cables trimmed in equal lengths to provide adequate separation and connection to GPSdome module. (See Step 2 in Installation Procedure below).

**Antennas** – locate and secure the antennas in full sky visibility, on the same horizontal plane, and with the same orientation for maximum GNSS signal reception.

### GPS Receiver System with GPSdome

The GPSdome module is integrated into the static or vehicle GPS receiver as shown in Figure 3. Two antennas are connected to the module (supplied antennas or locally purchased for permanent installation); the GPS antenna connects to primary input 'P' and an additional antenna connects to the auxiliary input 'A.'

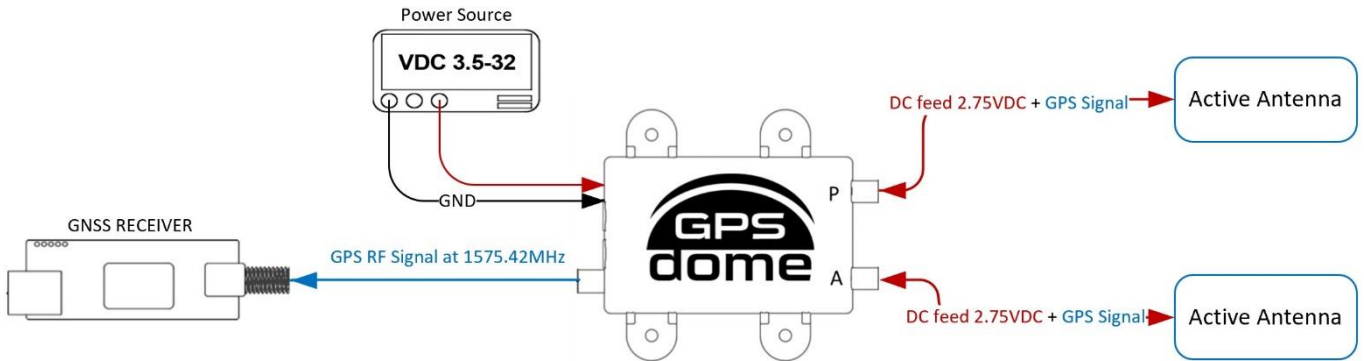

Figure 2 - GPS Receiver with GPSdome 1.03 - EPS Integrated

### SMA Cables Connectors

To prevent the risk of moisture ingress, it is recommended that a cable with high quality sealed SMA connectors (see figure below) is used to connect between the GPSdome module and the GPS receiver unit. Please use high quality RF cables with double shielded. Single shielded coaxial cable is not suitable. If alternative antennas are installed the same cable specification and SMA connectors are required.



Figure 3 - Unsealed vs Sealed SMA Connectors

## Installation procedure

### Step 1. Mount GPSdome

- Mark out and drill four holes suitable for M3 screws.
- Allowing for ease of cable connection, align the GPSdome to the holes.
- Secure the GPSdome using appropriate fixings (not included), such as four self-tapping M3 screws.

### Step 2. Installation of the Antennas

With reference to physical installation, the location of the two antennas to be fitted is as follows:

- Locate the antennas on a suitable area on a horizontal surface that always faces the sky, e.g. on the roof area.
- Mount the antennas with the same orientation (direction)
- Avoid placing the antennas near obstacles including roof racks, other antennas such as AM/FM and cell phone or air-conditioning devices that could block a clear view of the sky, preventing the satellite signals from reaching the antenna.
- Ensure that there is a distance of at least 15cm between the two antennas (nominally > 25 cm).

Route the antenna cables away from moving parts, under carpet and behind plastic trim, to the GPSdome module location.

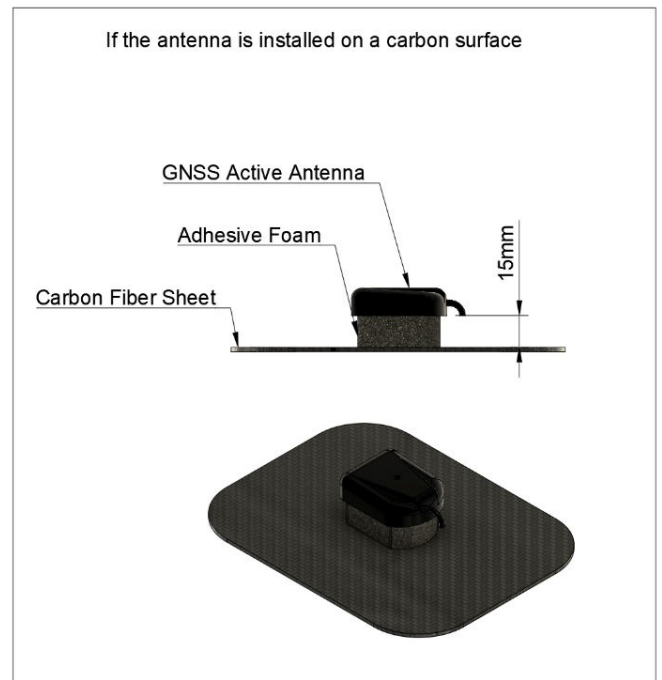
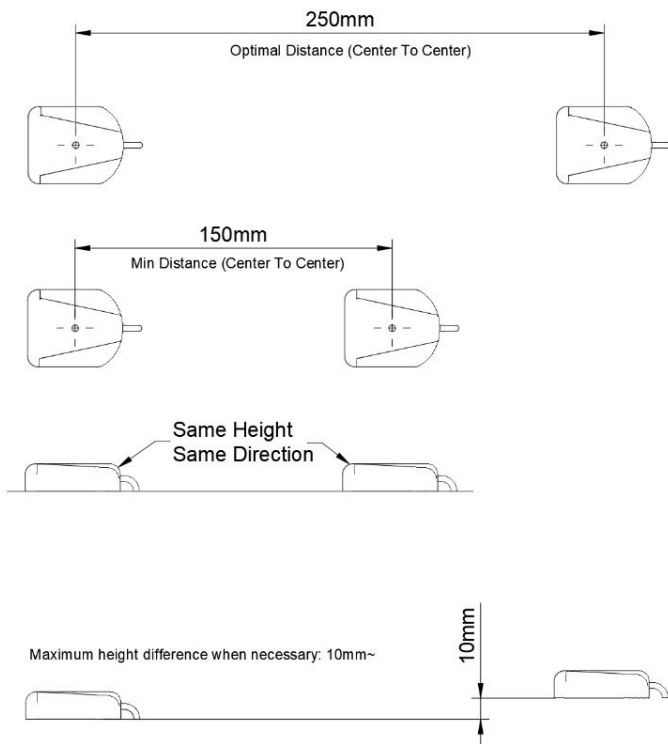





Figure 4 – GPSdome 1.03 - EPS - Operational Diagram

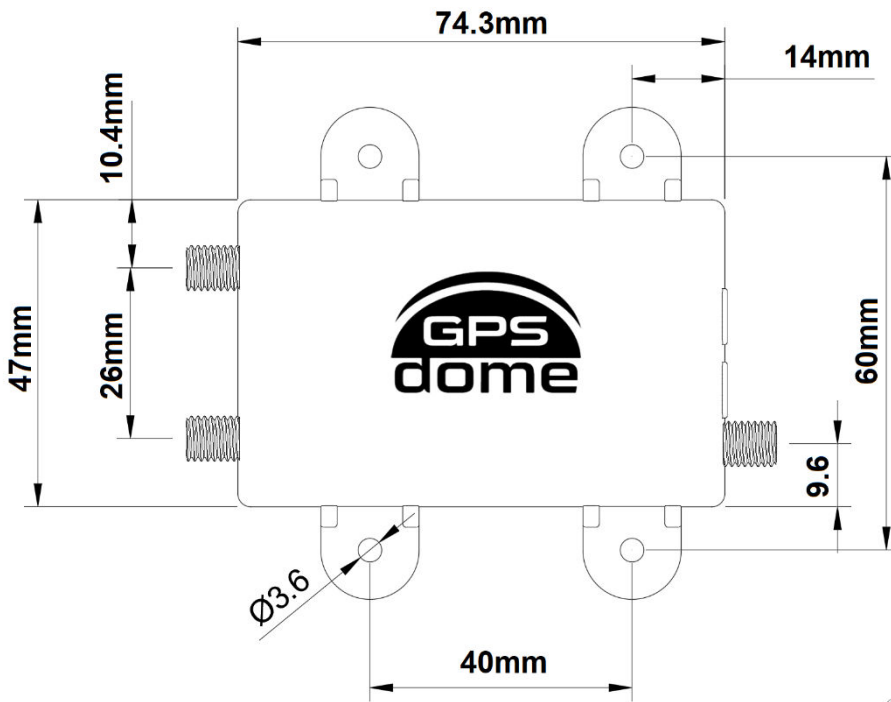
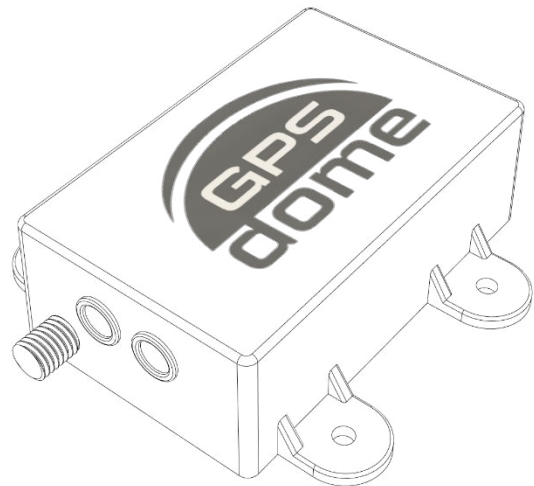

Figure 5 – GPSdome 1.03 - EPS – Product Dimensions





**To prevent damage to any cable assemblies used in this installation, ensure cables are not bent, deformed or snagged to cause damage to the internal wiring or the connector ends.**

**Tips:**

- Keep the cable between the GPSdome and the GPS receiver short.
- Locate the GPS antennas as far away from other RF jamming sources as possible.
- There are large variations in the performance of GPS receivers supplied by different manufacturers. GPSdome adds an anti-jam capability to all receivers, but the overall anti-jam performance of the combined system will depend on performance characteristics of the receiver.
- GPSdome reduces jamming signals that enter the receiver through the antenna port. However, a poorly - designed receiver can also absorb the jamming signal through the body of the receiver itself. A good receiver will have EMC shielding to prevent leakage of RF radiation through its sides; if this is not the case, and a better receiver can't be used, install the receiver in a shielded case.
- If possible, increase the distance between the GPSdome antennas and any jamming source. For example, if there is a jammer operating from the cigarette lighter socket in a car, locate the antennas towards the rear of the vehicle.
- If GPSdome is installed in a complex environment, such as a vehicle, experiment with the placement and orientation of the antennas for best results. Due to the complex propagation environments within vehicles, different installation options may produce a higher or lower performance.

**Step 4. Coax cabling**

Connect and secure the following cables to the GPSdome module using an SMA torque spanner set to 1Nm (8.85 in-lbs):

- a) Antenna 1 cable connector to the auxiliary antenna input 'A' connector.
- b) Antenna 2 cable connector to the primary antenna input 'P' connector.
- c) The RF output to receiver 'R' connector using a locally sourced cable fitted with high quality sealed SMA connectors. The other end connected into the GPS receiver RF antenna input.

**Step 5. External power supply**

Verify that the DC provided on the receiver cable is 3.7VDC - 32VDC and can provide at least 1W of power.

- a) Connect the red wire to +V (3.7VDC – 32VDC).
- b) Connect the black to common (GND).

- c) When interference indication is required, use the brown wire (and the same common – black), in accordance with interference indication.





**Caution: Make sure you connect the DC + to the red wire and the common/ground to the black wire.**

**Step 6.** Coil and secure any excess of antenna cable and power wires into a hidden location, such as under the carpet, using wire ties (not supplied).

### General Operation

GPSdome module operates without manual intervention.

Two LEDs located on the GPSdome module, provide the following indications:

LED indicators		
	LED1	When the module is powered ON and operating correctly, a green LED is steady on.
	LED2	When the presence of a jamming event is detected, a red LED is steady on.



## Help and Support

### General Specifications and Antenna Parameters

Table 1 - General Specifications

Item	Parameter	Description/notes	Value			Units
			Min.	Typ.	Max	
<b>Physical Operational Environmental</b>						
1	Temperature range		-40	25	+85	°C
<b>Default System Configuration</b>						
<b>RF Specification</b>						
2	Protected frequency	GPS L1		1575.42		MHz
<b>Power Supply Specification</b>						
3	Supply Voltage	Receiver DC line	+3.7		+32	Volt
4	Supply Consumption	Including antennas		1		Watt
5	Antenna Bias	Voltage		2.75		Volt
		Current per o/p		10	25	mA
		Self re-setting fuse		200		mA

Table 2 - Antenna Parameters

Item	Description	Value			Units
		Min.	Typ.	Max.	
<b>Type</b>	Active GPS Patch				n/a
<b>Elements</b>			2		n/a
<b>Gain</b>			30		dB
<b>Noise Figure</b>			2		dB
<b>Supply Voltage</b>			2.75		Volt
<b>Supply Current</b>		2	10	20	mA

## Maintenance

GPSdome does not contain any user-serviceable parts and contains no moving parts. With reference to the CAUTIONS on page 3, no maintenance is required apart from examining all the cable assemblies for secure connection, damage and corrosion.

## Troubleshooting

**Problem: Nothing is working, and my GPS receiver does not acquire lock**

Complete the following steps, in order:

- Check that there are no obstructions (e.g. buildings, tunnels) around or above the installation; move to another location as necessary.
- Isolate any internal jamming sources; switch off all other electronic devices.
- Check all cable connections for damage, excessive bending and that they are correctly secured.
- Check the GPS receiver functions correctly when connected directly to ONE antenna, without GPSdome connected. Repeat with the other antenna. If both antennas are confirmed as OK, then reconnect GPSdome.
- Check that the antennas are connected to GPSdome 'P' and 'A' connectors, and that the SMA connectors are tightened.
- Check that the GPSdome 'R' connector is connected to the GPS receiver, and that the SMA connectors are tightened at both ends.
- Check that 3.7VDC - 32VDC external power is connected from the GPSdome to an applicable power source.
- Check that the green LED is ON when an active GPS receiver is connected

## Interference Indication

The custom integrated circuit at the core of GPSdome has an open drain output to indicate the presence of jamming events. Its switch point is a function of external antenna LNA gain and so cannot be precisely specified.

*Note: Please note that this connection is optional*

### Interference Indication Integration Instructions

#### Indication specification

- Detection bandwidth: 1540MHz - 1602MHz
- Detection threshold: approximately -110dB (dependent on environmental factors)

In the diagram below (see left side of Figure 6), the "brown" wire is connected to an open drain circuit. Normally, without any interference like jamming, the Control FET is off. This means the jamming detection wire doesn't close the circuit for DC voltages. But if there's jamming, the Control FET turns on, connecting a 7.5k resistor to the ground.

In order to translate the interference indication (brown wire) to logic level signal, connect the brown wire to DC voltage in the customer equipment via pullup resistor.

#### Knowing issues

- inconsistent latency between passthrough frequencies and protected GPS L1 frequency.
- different insertion lost between passthrough frequencies and protects GPS L1 frequency.
- OEM MMCX connectors can pullout when disconnect the cable.

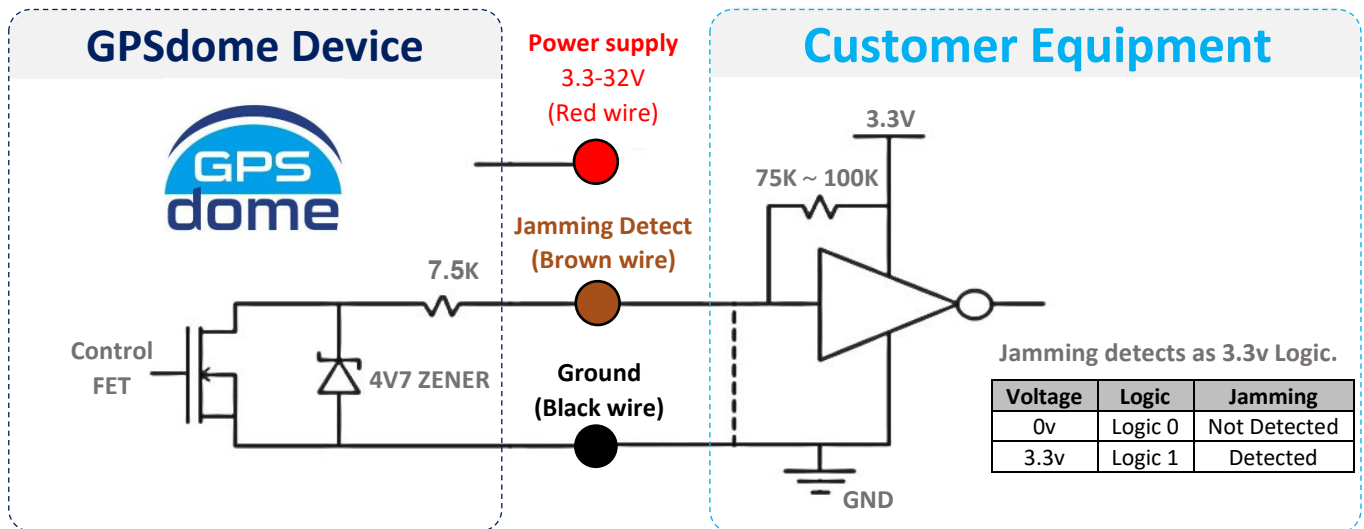

Figure 6 - Jamming Interference Detection Output Circuit

Email: [info@infinidome.com](mailto:info@infinidome.com)

## PPS\_installation

Installation of the PPS unit is very similar to the EPS unit. The only difference is that the PPS unit receives its power from the “R” connector, which can be supplied from either the receiver or from indiniDome’s Power over RF (PoRF) component.



The receiver must supply the PPS unit with power between 3.7VDC-32VDC in, min current of 1W, If the receiver cannot supply this, we can recommend providing the PPS unit power from PoRF.

### PoRF

the PoRF module provides power (DC) to the PPS (Phantom Power Supply) unit over the RF cable. As most installations of PPS units are on a roof of a building where no power source is available, the PoRF enables the GPSdome to be sufficiently powered over the RF cable.

The PoRF unit is mounted next to the GPS receiver or timing server. It is connected to the antenna port on the receiver, connected to a power supply via DC input, and connected to the antenna cable going to the roof where it will be connected to the GPSdome unit.



### specification:

Interfaces	
RF Connectors	BNC (F)
Power (3-24V)	3-24VDC (MATING PLUG 5.5mm * 2.1-2.5mm)

### Ordering Information

Product Name	Product Number	Description
Power Over RF Module.	1009	Feeds GPSdome / OtoSphere With Sufficient Power Over Antenna Cable.